

Cassina

413 CAB

Family **CAB**

Catalogue I **Contemporanei**

Year of production **1977**

"This was a new kind of chair, constructed totally out of leather, much cloned since then." Thus Mario Bellini describes Cab, a best-seller that he designed in the 1970s, which is now a signature piece in Cassina's I Contemporanei collection. Cab was the first-ever chair to feature a free-standing leather structure, inspired by how our skin fits over our skeleton. The pieces are sewn together only when their outer edges have been trimmed to ensure a perfect fit. Once assembled, the cover is attached to the chair's steel skeleton and held in place by means of a zipper fastening, as in a bespoke tailored garment. Today this model adapts and expands to meet contemporary needs. It is now available an XL model, 5cm deeper and 4 cm larger. Also available are new Plus saddle leathers in pure aniline, and some versions with a gradient effect by hand on a natural basis.

Gallery



Dimensions

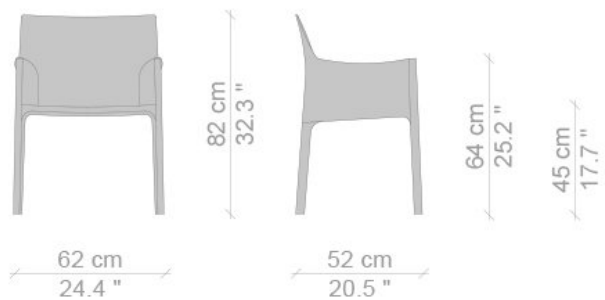
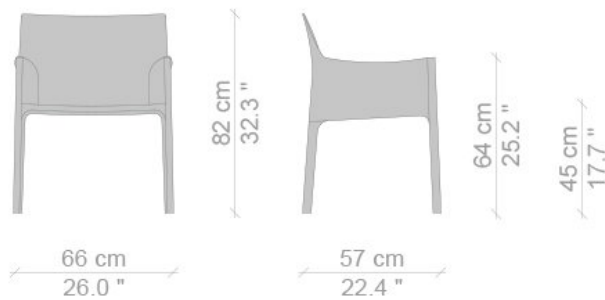

Designer

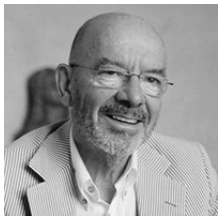

Mario Bellini

Mario Bellini is internationally renowned as an architect and designer. He has received the Golden Compass Award eight times, and other prestigious architecture awards including the Medaglia d'oro awarded by the President of the Italian Republic for his contribution to furthering design and architecture in the world (2004) and the Ambrogino d'oro for civic merit awarded by the City of Milan (2011).

He has given talks in many of the world's great cultural centres and was the editor of the magazine Domus from 1985 to 1991. He has 25 of his works in the permanent design collection of the New York Museum of Modern Art, which dedicated a personal retrospective to him in 1987.

He has held countless art, design and architecture exhibitions over the years, both in Italy and abroad. Since the 1980's, dedicating himself almost entirely to architecture, the manifold projects he has designed include the Portello Trade Fair district in Milan, the Villa Erba Exhibition Centre in Cernobbio (Como), the Tokyo Design Centre in Japan, the Natuzzi America Headquarters in the United States, the Essen Expo Centre in Germany, the National Gallery of Victoria in Melbourne, the headquarters of the Deutsche Bank in Frankfurt, the Verona Forum complex, the City History Museum in Bologna, the Department of Islamic Art at the Louvre in Paris, and the new Milan Convention Centre, the largest in Europe. Projects currently underway include the refurbishing works on the Brera Pinacoteca in Milan, while others nearing completion include the Erzelli Science and Technology Park in Genoa and the Civic Marble's Square in Carrara. He has various projects at the design stage, which include the "New Eco-City" of Zhenjiang in China and a large Residential, Cultural and Sports Complex in Qatar.